



DESCRIPTION

The FGT50 Bronze Gate Valve is designed for the isolation of clean water and other non-corrosive fluids that are compatible with the material of construction. It's generally used in building services, water treatment etc.

FEATURES

- Compact structure, reliable sealing
- Threaded bonnet
- Non-rising stem to minimize installation height
- Low pressure drop

TEST PRESSURE

- Working Pressure 175 PSI/CWP
- Seat Testing Pressure 350 PSI or 80 PSI Air
- Shell Testing Pressure 350 PSI or 80 Air

SPECIFICATION

- Certification: UL Listed
- Connection Standard: ANSI B1.20.1 NPT BS21. BSPT
- Medium: Water

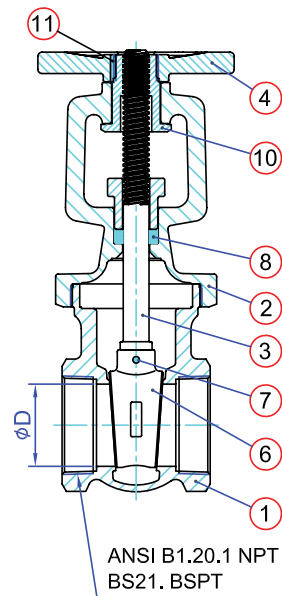
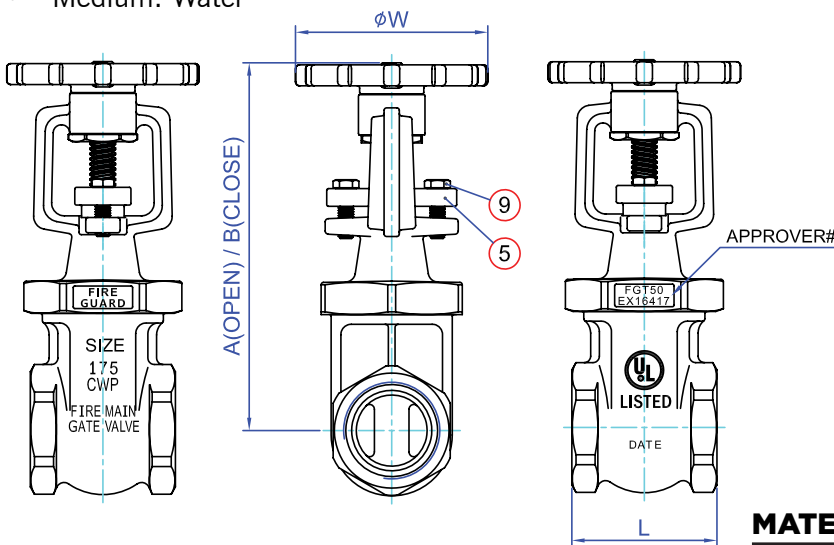

DIMENSION

SIZE	A±3	B±3	L±0.5	D	W±3
3/4"	173	145.5	59	20	80
1"	196.5	163	69	25	80
1-1/4"	220.5	181.5	75	32	80
1-1/2"	243	197	82	37.5	100
2"	282	227	90.5	50	120

MATERIAL LIST

No.	PART NAME	MATERIAL	QTY
1	Body	Bronze ASTM C83600	1
2	Bonnet	Bronze ASTM C83600	1
3	Stem	Brass	1
4	Handwheel	Cast Iron	1
5	Packing Gland	Bronze ASTM C83600	1
6	Disc	Bronze ASTM C83600	1
7	Disc Pin	SS-304	1
8	Gland Packing	Graphite	1
9	Stud	Steel	2
10	Yoke Bushing	Brass	1
11	Set Screw	Steel	1